

FUME GURU CARBO VOC

PORTABLE VOC FUME EXTRACTOR



With 10' capture arm
650 CFM

Volatile Organic Compounds (VOCs) fumes and odors present a serious workplace hazard that need to be captured and filtered with a portable fume extractor. The Fume Guru Carbo VOC is designed to extract VOC fumes and odors and prevent them from entering an operator's breathing zone.

The Fume Guru Carbo VOC's high porosity activated carbon granules are specially designed to adsorb most industrial VOC fumes. The carbon cartridge is reversible allowing you to utilize 100% of the available media to remove airborne fumes and is available in five standard weight configurations.

The extractor arm's pantograph style articulation ensures ultra-smooth repositioning and protects the arm's components from wear and tear. The high performance blower develops a powerful face velocity to ensure fumes are eliminated from the workspace.

Features:

- Flexible 10' externally articulated capture arm
- 1.0 HP TEFC motor producing 650 CFM at the hood
- Carbon canisters
- 15" power cord & casters

Benefits:

- Compact, portable, 120 volt, single phase
- Capture-at-source for cleaner air
- Complies with OSHA guidelines for controlling VOCs

Carbon Filter

CARBOTECH 75

Reversible steel canister filled with 66 lbs of activated carbon to filter VOC fumes and odors. Double the filter life by flipping the canister top-to-bottom, allowing for adequate contaminant distribution through the media.



S-CCX-75R

WEIGHT: 66 LBS
FILTER MEDIA: ACTIVATED CARBON
PREFILTER MEDIA THICKNESS: 0.79"
COVER: 3/4" ANTIBACTERIAL
END CAP: TWIST LOCK REMOVABLE
CLEANING METHOD: NONE
MAX TEMP: 175° F / 80° C

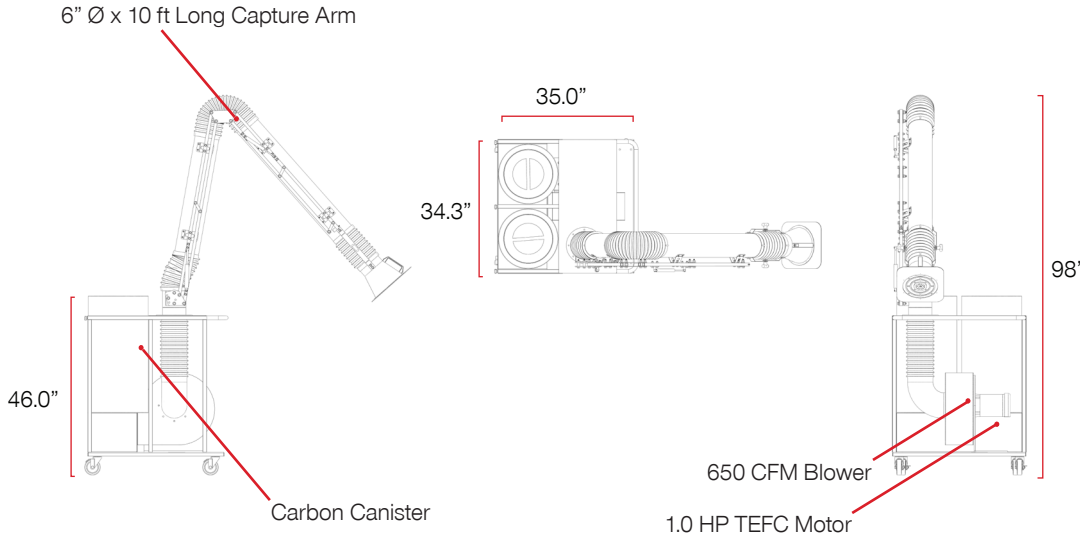

Dimensions **

Model	Arm Length (ft.)	Arm Diameter (in.)	Product Dimensions (in.)		
			Width [a]	Height [C]	Length [b]
Fume Guru Carbo VOC Extractor with externally articulated manual capture arm					
Fume Guru Carbo VOC	10	6	34.3	98	35
	13	6	34.3	98	35

** Product dimensions are based on base-models and may vary depending on selected product features. Please contact us for an accurate shipping quote.

Technical Specifications

Model	Motor (H.P.)	Power		Airflow (CFM)	Carbon Capacity (lbs.)
		Phase (hz)	@120V (amps)		
Fume Guru Carbo VOC Extractor with externally articulated manual capture arm					
Fume Guru Carbo VOC	1.0	1P/60Hz	16	650	150