

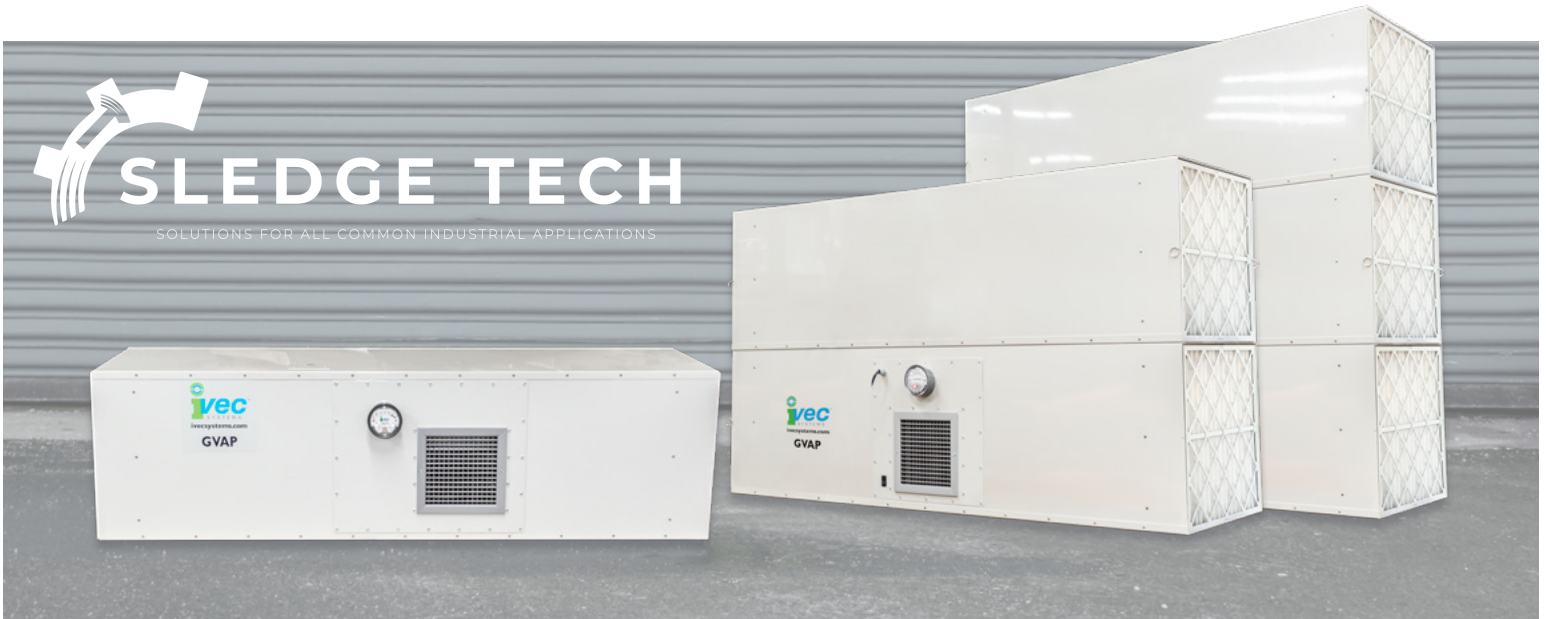

# SLEDGE TECH

SOLUTIONS FOR ALL COMMON INDUSTRIAL APPLICATIONS



## IVEC GVAP SERIES COLLECTORS

GENERAL VENTILATION ALL PURPOSE

**Protect you and your environment while controlling your budget**

The IVEC GVAP is a plug & play ambient air cleaner designed to filter the air of fine, airborne dust, and contaminants to provide higher quality air, protecting the health of your employees and your environment. The GVAP is the most efficient ambient air cleaner in its class saving you money by lowering energy consumption and maintenance costs. With no need for ducting, this compact, versatile system can be hung from the ceiling or mounted to the wall and requires no floorspace.

### **COST REDUCTION GUARANTEE BY IVEC®**

- Low Up Front Cost per CFM
- Direct Drive increases the efficiency by up to 23% over belt drive units
- Low Installation (Plug & Play) and Maintenance Costs
- Lower Energy Costs by up to 70% with smart controller option

### **ADVANTAGED OPERATING CHARACTERISTICS**

- Direct Drive for Added Reliability
- Modular / Scalable Design
- Easy In / Out Filters
- Nominal filter sizes
- Easy Maintenance
- Improved Filter Life

### **Applications**

Wood Dust, Coolant Mist, Ceramic Dust, Printing Powder, Plastic Smoke, Sanding Dust, Dry Chemicals, Grinding Dust, Oil Smoke, Weld Smoke, Powders, Rubber Dust, Mineral Dust

CLEAN AIR. ONLY SMARTER.



# IVEC GVAP SERIES COLLECTORS

## What is the advantage of direct drive blower system vs. typical belt driven units?

Improperly maintained belt driven units are up to 23% less efficient than direct drive blowers which increases filter costs, drives up maintenance, and increases energy consumption.

## Ever wonder, "Is my GVAP System cleaning air properly & efficiently?"

By upgrading to the IVEC intelligent control system option, you will be able to optimize and manage your system automatically. The optional smart controller routinely adjusts power and fan speed to ensure optimized air cleaning operation. Let IVEC optimize your air flow and save you money in the process!

## Why choose IVEC Products?

IVEC uses automated control technology to add capacity with fewer units, reduce fan noise, extend filter life and the life of the equipment; all of which save you money.



Shown with optional Magnehelic pressure gauge & mounting kit

MODEL	CFM	POWER (HP)	VOLTAGE (V)	FLA (A)	FIBERGLASS BAG FILTER, TOTAL FILTER AREA (ft <sup>2</sup> )	PLEATED PRE-FILTERS, TOTAL FILTER AREA (ft <sup>2</sup> )	AIR TO CLOTH RATIO	WEIGHT* (lbs)	H x W x D
GVAP3000S	3000	0.75	120	9.5	138	47	22:1	225	24x24x85
GVAP3200H2	3200	0.75	120	9.5	276	94	12:1	375	24x48x85
GVAP4000S	4000	3	208/230/460	10.6/9.6/4.8	118	47	34:1	300	24x24x85
GVAP4500H2	4500	3	208/230/460	10.6/9.6/4.8	236	94	19:1	450	24x48x85
GVAP4500H3	4500	3	208/230/460	10.6/9.6/4.8	354	141	13:1	600	24x72x85
GVAP45002X2	4500	3	208/230/460	10.6/9.6/4.8	472	188	10:1	750	48x48x85

\* Weight is approximate | Fiberglass Filter Efficiency: 65%/95% | Optional Pressure Gauges Available | 2HP model available upon request

## Optimize your Air Cleaning

Smart Controller  
Magnehelic Gauge

Mounting Kit  
Carbon Filter

Pre-filter Wrap  
Silencer

Mist Collection Tray  
Smart Controllers/IPS

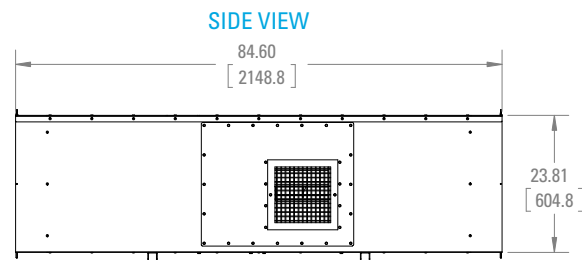
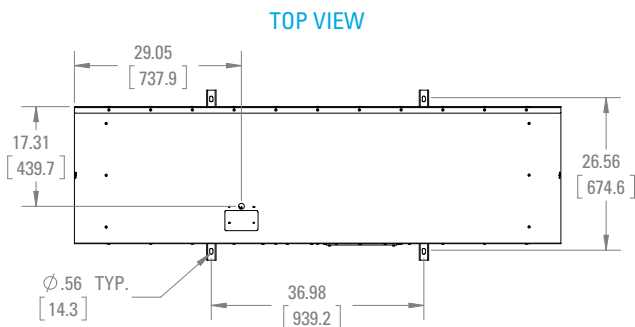

Sledge Tech | (706) 622-3039 | [www.sledge-tech.com](http://www.sledge-tech.com)

